

Parameter	All Versions
Supply Voltage	11.5V DC min. - 32 VDC max.
Supply Current	45 mA max. (no load)
Input Control Signal	
Control Voltage	0 - 10 VDC (500 K Ω impedance)
Control Current:	0 - 20 mA (100 Ω impedance)
Regulation ΔV	+/- 0.2% / V
Regulation ΔT	+/- 0.1% / °C
Ramping Up/Down Time	0.1 - 20 sec. linear (+/- 0.1% / °C)
PWM Frequency	95 - 225 Hz
Output Leap to I min.	@ 0.2 V or 0.4 mA control (+/- 15%)
Operating Temp.	-25 to 85° C

Parameter	High Resolution Version	High Output Version
	Output Current @ 25° C T _A	
Continuous	1.5 Amps max.	3.0 Amps max.
Peak Pulsed (16ms)	4.7 Amps max.	17.0 Amps max.
I min. (+/- 20%)	0 - 0.5 Amps max.	0 - 1.0 Amps max.
I max. (+/- 20%)	I min. + 1.0 Amps max.	I min. + 2.0 Amps max.

Troubleshooting

If the set up procedure does not achieve the desired results, double check the wiring and perform the following tests.

Check the power input:

The card will not function correctly unless the Supply Voltage is at least 11.5V. If this voltage is more than 32V the card may be damaged.

Check the control input you are using:

- Pot input: Measure the wiper voltage between the Command Voltage (pin 3) and Supply Voltage (pin 2) terminals. With a 10K ohm pot, the wiper will go from 0 (minimum current) to 8.0V. The voltage must not be less than 0V or more than 9V.
- Voltage input: The difference in voltage between the Command Voltage (pin 3) and Supply Voltage (pin 2) terminals should be greater than 5V from minimum to maximum. The voltage must not be less than 0V or more than +10V.
- Note: Only one control input may be hooked up at a time.

Verify the coil is not shorted:

Disconnect the wires going to the coil terminals and measure the resistance between the wires. Verify it is correct for the coil being driven.

Check the card at full on and full off:

Do not try the full on test if the power supply is 50% higher than the coil's rated voltage. Temporarily disconnect all wires from the Command Voltage (pin 3) and Command Current (pin 4) inputs. To test the card at full on, turn the I MAX and I MIN pots 15 turns CW and temporarily apply a 10V command signal to pin 3. Measure the voltage across the Coil Output terminals and across the Supply Voltage pin 1 and pin 2 terminals. The voltage difference should be no more

than one volt if the card is operating correctly. To check the card at full off, disconnect the Command Voltage (pin 3). The Coil Output voltage should be zero.

If the valve won't fully shift:

- If the card passes the "full on test" above, the problem is in the system. Measure the power supply voltage at the power supply or battery and the voltage across the coil's terminals. Compare these readings to the values taken at the card. If there is excessive voltage drop in any of those wires, they should be shortened or replaced by bigger wires. Bad frame ground connections can cause large voltage drops.
- When the coil heats up in use, it increases its resistance. Most coils will still be able to draw sufficient current to fully shift the valve if their rated voltage is supplied to the card and the card causes less than one-volt drop. When this is not the case, you must use a coil rated for less voltage or increase the power supply voltage. The card will have no trouble driving a 12V coil from a 24V supply. You will need a new card if the new coil draws more current than the card is rated for.

If the valve shift is erratic:

- See the set up procedure section for the effects of stiction and hysteresis. Adjust the dither amplitude to see if it improves the problem.
- Electrical interference on the control lines can also cause erratic behavior if it is strong enough. Try changing the routing of the control wires to see if the problem changes.
- Power supply interference or brown outs can also cause erratic behavior. Test for this by running the card off it's own fully charged battery.



canfield connector
 8510 Foxwood Court
 Youngstown, Ohio 44514
 (330) 758-8299 Fax: (330) 758-8912
 www.canfieldconnector.com

MICRO PROPORTIONAL DRIVER
 INSTALLATION GUIDE

SERIES 5950

Hook-Up Diagram

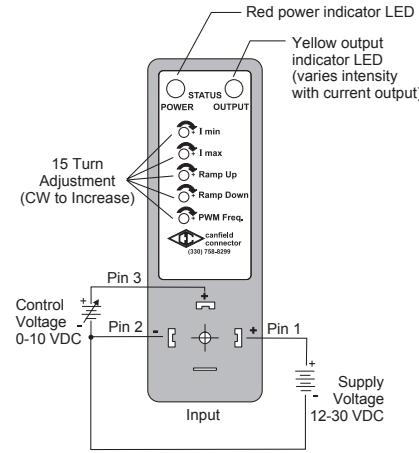

Top Control Option 0 using Voltage Control

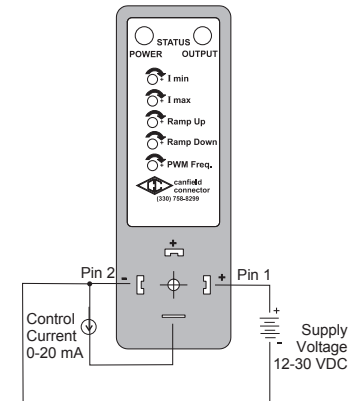

Top Control Option 0 using Current Control

Note: (Polarity Protection on 1.5 A Version Only)

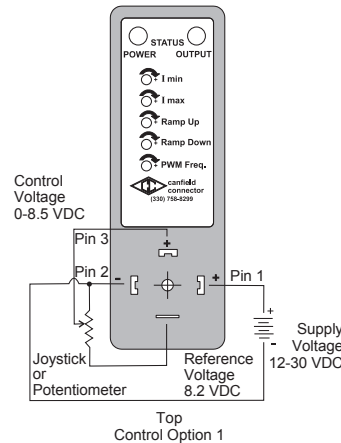

Top Control Option 1



Output (To Valve)
 Bottom

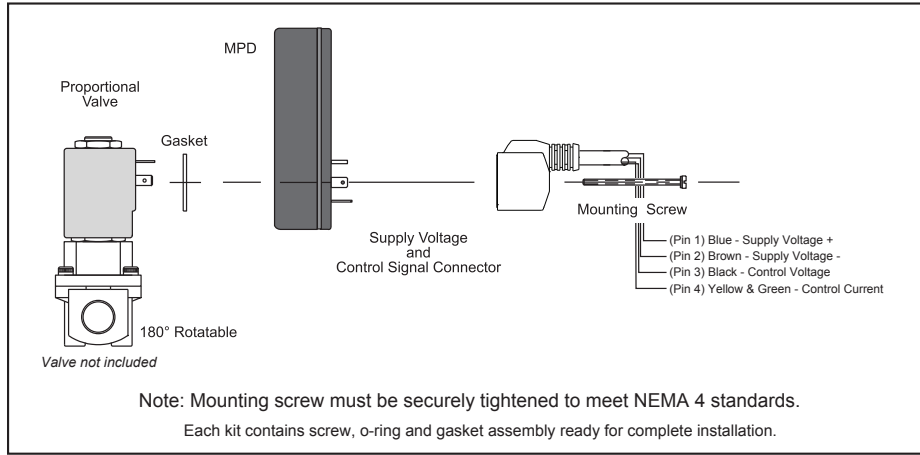

Set-Up Procedure

The unit is best adjusted by observing the system response. Coil current can also be used, but coil voltage is not accurate.

Control Option 0

Control input will be used to describe the input from a driver card, a PLC, or analog sensor that will control the functionality of the MPD. Please note that only one of the following methods can be used at the same time. Using voltage as the control input, make connections from Control Voltage (pin 3) to Supply Voltage (pin 2), making certain to use 0-10VDC (500K Ω input impedance). Using current as the control input, make connections from Command Current (pin 4) to Supply Voltage (pin 2), making certain to use 0-20 mA (100 Ω input impedance).

Control Option 1

If not wanting to use an external control input, connections may be made using a 10K - 100K % impedance pot or a joystick connected from 8.2 VDC reference (pin 4) to Supply Voltage (pin 2), and then making connection from the wiper of the pot to Control Voltage (pin 3).

Minimum Current & Maximum Current

These two adjustments will vary the minimum and maximum output current limits. The minimum current can be set between 0-0.5 A for the standard version (0-1.0 A for the high output version). The maximum current can be set in the range between the minimum current setting and the minimum current setting plus 1 A for the standard version (2A for the high output version). The minimum current must be set first as described below. Always adjust the I MIN

or I MAX pot until the response starts changing and then adjust to the desired response.

1. Turn the I MAX, I MIN, PWM FREQ and RAMP UP, RAMP DOWN pots 15 turns CCW.
2. Turn on the power supply. The PWR light will come on if the power supply voltage is greater than 11.5 volts. The unit will not function correctly if the POWER indicator light is off or blinking.
3. The OUTPUT Indicator light indicates the duty cycle of the voltage to the coil by going from no light, always off, through bright yellow, always on. The intensity of the yellow gives a relative indication of current flow through the coil as an aid to tuning and troubleshooting.
4. Set the control input to minimum, (.2V or etc.). **Minimum Current Adjustment** - Adjust the min current adjuster for a minimum current or to a desired system response. Back up adjuster until system stops responding. Proceed to max current adjuster. The I MIN pot can eliminate the valve's deadband.
5. Adjust the I MAX pot 15 turns CCW. Set the control input to its maximum, (or 10V or etc.). **Maximum Current Adjustment** - Adjust max current adjuster for a maximum current limit or to a desired system response. The I MAX pot adjusts the maximum valve shift. Do not adjust the unit for more current than is required to fully shift the valve; this reduces the useful range of the control input and may harm the coil.

Note: To minimize any effect of supply voltage, load resistance or temperature variation; make setup adjustments when these parameters are at the midpoint of the expected operating range for a particular installation. For example, if the expected operating temperature range is 20°C to 60°C make final setup adjustments when system is approximately 40°C. If the supply voltage has a tolerance of 22 to 32 volts, make adjustments when the supply voltage is approximately 27 VDC.

6. Ramp Up/Ramp Down - Set the **RAMP UP** pot to the desired value by quickly switching the control input from minimum to maximum, while observing the speed of response. Set the **RAMP DOWN** pots the same way, but going from maximum to minimum. Turning the ramp pots CW will increase the ramp time. The ramps slow down the system's response to fast control input changes. Range of ramp up/ramp down time adjustments is 0.10 - 20 sec. Ramp time is linear and is proportional to the step change in the control signal.

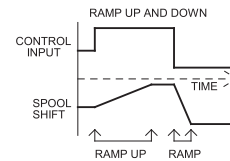

7. **PWM Frequency** - The MPD uses an adjustable works frequency for dithering. The works dithering method uses a low frequency for coil drive and dithering. The output is pulse-width modulated to control output current within the minimum and maximum current settings. This PWM Frequency adjustment is continuously variable in the range of 95-225 Hz. When shipped, the frequency adjustment is left at maximum. Adjust the frequency of the PWM to a low enough value to cause a slight movement or hum. Too low a PWM frequency can cause pulsing in the system.

- **Stiction** can keep the valve from moving for small control input changes, and then move too far when the control input changes enough to unstick it.
- **Hysteresis** can cause the valve shift to be much different for the same control input depending on whether the control had last changed up or down.
- **Dither** is a rapid, small movement of the

valve about the set point. It is intended to keep the valve moving to avoid stiction, and to move far enough to cancel out hysteresis, while being small and fast enough not to be noticed by the system.

- **Reference Voltage** is a regulated 8.0 VDC voltage available for on site command voltage. Use of a 10K - 100K potentiometer connected from the 8.0 VDC Reference to Supply Voltage (-) is recommended.
- **Output** is current regulated and will remain constant at the level set by the input command signal. Variations in supply voltage and load resistance have little effect as long as these values satisfy the equality stated below. Polarity must be observed if the coil has an internal diode. The output is pulse-width modulated to control output current within the minimum and maximum current settings. The frequency of the modulation is fixed at 1.2 KHz.

$$\text{Max. Required Currents} \leq \frac{\text{Min. Supply Voltage}}{\text{Max. Load Resistance}}$$

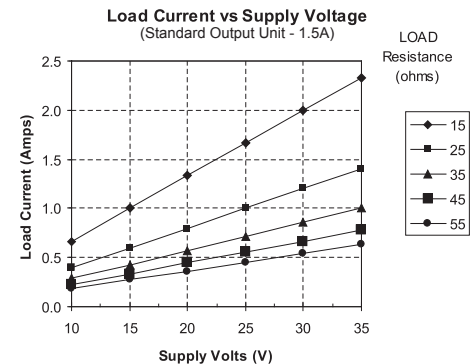

Use the graph above to aid in determining supply voltage requirements versus load current for the resistance of the device being controlled. For example, if the required load current is 1 Amp and the load resistance is 25 ohms, then the minimum required supply voltage is 25 V. Alternatively, if the load resistance is only 15 ohms, then the minimum required supply voltage is 15 V. The load resistance line must fall within the area below the maximum required load current and to the left of the minimum supply voltage. In determining maximum resistance, changes due to temperature must be taken into consideration. The proportional driver will limit the output current to the 1.5 or 3.0 Amps design limit.